

COPY



AIRTRONICS[®] INC

VANGUARD FM 6H

RADIO CONTROL INSTRUCTION MANUAL



VANGUARD FM 6H

TABLE OF CONTENTS

- SECTION I Safety First for Yourself and Others
- SECTION II Federal Licensing Requirements and Special Operating Standards for Model Airplanes
- SECTION III System Features
- SECTION IV Unpacking and setting up your AIRTRONICS VANGUARD FM 6H Radio Control System
- SECTION V Operation and Adjustments

NOTE: FOR BATTERY CHARGING INFORMATION AND INSTRUCTIONS ON LEARNING TO USE YOUR AIRTRONICS RADIO CONTROL SYSTEM, PLEASE SEE THE AIRTRONICS INSTALLATION FUNDAMENTALS AND GUIDELINES MANUAL.

THANK YOU FOR SELECTING AIRTRONICS!

We appreciate your purchase of this new AIRTRONICS VANGUARD FM 6H RADIO CONTROL SYSTEM.

These instructions are intended to acquaint you with the many unique features of this modern, state-of-the-art equipment. Please read them carefully so that you may obtain maximum success and enjoyment from its operation.

We ask that you pay particular attention to the design of the transmitter.

Notice that it has been human engineered for the most natural and precise control of your choice of flying models.

Be certain to read all of the material in this manual, as well as that in the Fundamentals and Guidelines Manual.

SECTION I

SAFETY FIRST, FOR YOURSELF, FOR OTHERS AND FOR YOUR EQUIPMENT

"SAFETY FIRST" is more than just a slogan when operating radio controlled models. Thus, we urge, especially with respect to radio controlled aircraft that:

FOR YOUR SAFETY:

Recognize that radio controlled models are not harmless toys and can be dangerous missiles if carelessly or improperly flown. You are responsible because the reliability and safe

operation of the radio equipment is largely dependent upon its proper installation and utilization.

THEREFORE, INSTALL YOUR RADIO CONTROL SYSTEM CORRECTLY AND BE CERTAIN YOU CAN FLY WELL ENOUGH TO CONTROL YOUR AIRCRAFT UNDER ALL CONDITIONS.

FOR YOUR SAFETY AND THE SAFETY OF OTHERS:

Remember that you are responsible for the safety of all spectators and, in fact, everyone that may foreseeably be injured by your model.

DO NOT FLY where your model could injure any person or property.

DO NOT FLY over the heads of spectators or persons in the area of your flying field. **THIS INCLUDES** taking off, actual flight and landing. **KEEP EVERYONE**, except experienced and knowledgeable persons who are assisting you in flying, away from your model even when it is on the ground and you are preparing to fly.

DO NOT FLY unless and until you have an experienced instructor who has completely **CHECKED OUT THE MODEL AND WILL FLY THE MODEL FOR YOU AND WITH YOU . . . UNTIL YOU HAVE LEARNED TO FLY COMPETENTLY BY YOURSELF.**

Flying is a real skill that demands patience, practice and caution. **DO NOT EXPERIMENT** or run **RISKS**. **KNOW** that you can fly safely before you fly alone. The real pleasures and satisfactions come from flying or operating your model with **SAFETY** and competence always in mind.

DO NOT FLY in adverse weather conditions. Strong winds, for example, may cause loss of control of your aircraft and cause injury or damage to you or to others.

AT THE FIELD . . .

DO NOT FLY unless your frequency is "clear." The transmitting signal channel (frequency) is shown on the transmitter and **YOU MUST NOT** turn on your transmitter when someone is flying or operating their model on that same frequency. **WARNING: IF YOU DELIBERATELY OR ACCIDENTALLY TURN ON YOUR TRANSMITTER WHILE ANOTHER MODEL IS FLYING OR IN OPERATION, THAT MODEL WILL GO OUT OF CONTROL.** The same will happen to yours, so observe "clearing" the frequency: Only one person using a given frequency at a time. **DO USE CHANNEL IDENTIFIER (FREQUENCY) FLAGS** for the frequency your system uses and attach the appropriate flags to your transmitter antenna. **DO OBSERVE** all of the rules of the flying or operating site.

The channels and frequencies associated with them are as follows:

72 MHz Band (Aircraft Only)

<u>CHANNEL NUMBERS</u>	<u>FREQUENCY</u>
CH 12	72.030
CH 38	72.550
CH 40	72.590
CH 42	72.630
CH 44	72.670
CH 46	72.710
CH 48	72.750
CH 50	72.790
CH 52	72.830
CH 54	72.870
CH 56	72.910

CHANNELS 14 THROUGH 34 WERE ADDED JANUARY 1, 1988. Narrow band transmitters are required to operate on Channels 12 through 34 inclusive. Channel number plaques are used to identify a specific channel in the 72 MHz band. The VANGUARD FM 6H meets narrow band requirements.

<u>CHANNEL NUMBER</u>	<u>FREQUENCY</u>
CH 14	72.070
CH 16	72.110
CH 18	72.150
CH 20	72.190
CH 22	72.230
CH 24	72.270
CH 26	72.310
CH 28	72.350
CH 30	72.390
CH 32	72.430
CH 34	72.470

WARNING: The 72 MHz frequencies above are allocated for Model Aircraft use, and are exclusive: however, they are in close proximity to other types of radio use in certain areas. Before operating your model, check with the Federal Communications Commission (FCC) Regional Office in your area to determine whether there is potential danger of interference from other radio users. If you are flying at a site regularly used by a club or other modelers you should also check with them if there are any frequencies that are known to have interference problems at that site. "Outside" radio interference may cause you to lose control of your model, possibly causing injury to yourself, to others, or to property.

There are also 75 MHz Channels assigned by the FCC for use with model cars, boats, etc.

YOUR AIRTRONICS RADIO MEETS AND EXCEEDS ALL PUBLISHED REGULATIONS AND GUIDELINES CONCERNING THE PERFORMANCE OF R/C EQUIPMENT. IT IS YOUR RESPONSIBILITY TO BE SURE THE AREA WHERE YOU OPERATE YOUR EQUIPMENT IS FREE FROM OUTSIDE INTERFERENCE. AIRTRONICS CAN NOT BE HELD RESPONSIBLE FOR DAMAGE TO EQUIPMENT OR PERSONS CAUSED BY A LOSS OF CONTROL DUE TO RADIO INTERFERENCE. REMEMBER THE FOLLOWING POINTS FOR PROPER FREQUENCY USE:

1. DO NOT OPERATE your transmitter at the field until

2. DISPLAY your channel identification plaques on the antenna of your transmitter.
3. REMEMBER that channel identifier plaques do not usually state the frequency on them. Ask and be certain. If you have eyesight limitation, double check to be sure of channel plaque designations.
4. Turn your transmitter on only when you are sure no one else is using your frequency.
5. **WARNING:** Your model will go out of control and may do serious injury or damage if someone else turns on a transmitter on your frequency while you are operating your model.
6. Respect all the rules of the flying field or site.
7. At anytime during the operation of your model, should you sense, feel or observe any erratic operation or abnormality, end your flight as quickly and as safely as possible. DO NOT operate again until you are certain the problem has been corrected. TAKE NO CHANCES.

ADDITIONAL WARNING:

Radio controlled models are generally attractive, exciting and inviting in looks and performance. Realize that young persons, and inexperienced adults may try to operate the equipment without understanding the dangers to that person or others. It is your responsibility to guard against unskilled and unknowing hands for their protection as well as for the safety of your equipment and model.

The key to R/C pleasure is the proper use of your System and all of the other model components. If you fail to follow instructions, heed the warnings given, misuse or abuse the system through improper operation or installation, the consequences may be harm or destruction of your system, or injury to yourself or the person or property of others.

AS TO YOUR EQUIPMENT:

The care you give your radio control equipment, and to its correct installation and operation, are the factors that make the difference between safe, successful flying or injury, damage, destruction and loss.

ACADEMY OF MODEL AERONAUTICS (AMA)

The Academy of Model Aeronautics is the leading national organization made up of aircraft modeling people with headquarters near Washington, D.C. Its address is 1810 Samuel Morse Drive, Reston, VA 22090, and we urge you to examine the benefits of membership including liability protection in the event of certain injuries. The Academy has adopted simple and sane rules, a few which are especially pertinent for radio controlled flight as the OFFICIAL AMA SAFETY CODE. Abide by these rules for your protection, the protection of others and your equipment. Excerpts are as follows:

1. I will not fly my model aircraft in competition or in the presence of spectators until it has been proven to be airworthy by having been previously successfully flight tested.
2. I will not fly my model higher than approximately 400 feet within 3 miles of an airport without notifying the airport operator. I will give right of way to and avoid

- flying in the proximity of full scale aircraft. Where necessary, an observer shall be utilized to supervise flying to avoid having models fly in the proximity of full scale aircraft.
3. Where established, I will abide by the safety rules for the flying site I use, and I will not willfully and deliberately fly my models in a careless, reckless, and/or dangerous manner.
 4. I will have completed a successful radio equipment ground range check before the first flight of a new or repaired model.
 5. I will not fly my model aircraft in the presence of spectators until I become a qualified flyer, unless assisted by an experienced helper.
 6. I will perform my initial turn after takeoff away from the pit or spectator areas, and I will not thereafter fly over pit or spectator areas, unless beyond my control.
 7. I will operate my model using only radio control frequencies currently allowed by the Federal Communications Commission. (Only licensed amateurs are authorized to operate equipment on amateur band frequencies.)

NOTE: These basic safety precautions are for your safety, the safety of others, and of your equipment. Consider carefully all of what has been stated and obey all precautions as well as those appropriate to your particular use. Good common sense must also be used at all times in the operation of your equipment.

SECTION II

FEDERAL LICENSING REQUIREMENTS AND SPECIAL OPERATING STANDARDS FOR MODEL AIRPLANES

The Federal Communications Commission no longer requires a license to operate an R/C model transmitter.

However, the Federal Aviation Administration has announced guidelines for operation of model aircraft. We are reprinting those guidelines here and encourage you to study and follow them.

1. Purpose: This advisory circular outlines safety standards for the operators of model aircraft and encourages voluntary compliance with these standards.
2. Background: Attention has been drawn to the increase in model aircraft operations, and the need for added caution in the case of free-flight and radio controlled types to avoid creating a noise nuisance or a potential hazard to full-scale aircraft and persons and property on the surface.
3. Operating Standards: Modelers, generally, are concerned about safety and do exercise good judgement when flying model aircraft. However, in the interest of avoiding undue criticism from affected communities and airspace users, **COMPLIANCE WITH THE FOLLOWING STANDARDS IS ENCOURAGED BY OPERATORS OF RADIO CONTROLLED AND FREE-FLIGHT MODELS.**
 - a. Exercise vigilance for full-scale aircraft (get other people to help if possible) so as not to create a collision hazard.

- b. Select an operating site at a sufficient distance from populated areas to avoid creating a noise problem or potential hazard.
- c. Do not fly higher than 400 feet above the surface.
- d. Do not operate closer than three miles from the boundary of an airport unless permitted to do so by the appropriate air traffic control facility in the case of an airport for which a control zone has been designated, or by the airport manager in the case of other airports.
- e. Do not hesitate to ask for assistance in complying with these guidelines at the airport traffic control tower, or air route center nearest the site of the proposed operations.

Director, Air Traffic Service
Federal Aviation Administration
Washington, D.C.

Under SAFETY, we encourage your participation in the Academy of Model Aeronautics as a member. Many flying fields require that you be a member of the Academy of Model Aeronautics before they will allow you to use their field. They want to know that all pilots are knowledgeable concerning the AMA SAFETY CODE and through membership have the liability insurance.

SECTION III

VANGUARD FM 6H FEATURES

TRANSMITTER

- High Power (500 Milliwatt)
- Advanced Gimbal Design, with Control Stick Length and Tension Adjustment
- Expanded Scale Voltmeter
- Internal Plug-in NiCd Transmitter Battery
- Up/Down Two-Way Revolution Mixing
- Pitch Trim Adjustment
- Two Position Gyro Sensitivity Switch or Landing Gear Function Switch
- Servo Reverse Capability on all Primary Channels
- Throttle Hold Capability
- Dual Rate on Elevator and Aileron
- Hovering Pitch Trim Adjustment Knob
- Attractive Satin Chrome, and Black Plastic Case with Internally Collapsible Ten Section Antenna
- Idle-Up Function Switch

RECEIVER

- Dual Conversion 6 Channel FM Narrow Band Receiver of Advanced Design to achieve Outstanding Range, Noise Suppression, and Adjacent Channel Rejection.

SERVOS

- The VANGUARD FM 6H is available with standard Hi-Torque Servos as well as with Optional High Performance Airtronics contest Servos.

AIRTRONICS VANGUARD FM 6H

TRANSMITTER FEATURES AND FUNCTIONS

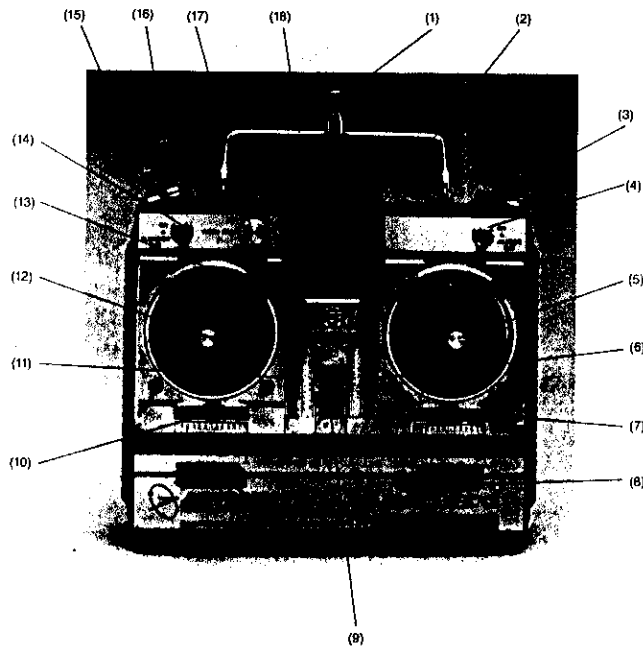

The AIRTRONICS VANGUARD FM 6H Radio Control System is primarily intended for the flying of rotary wing model aircraft.

1. Retractible Antenna
2. Expanded Scale Voltmeter
3. Idle-Up Switch
4. Aileron Dual Rate Switch
5. Control Stick, Horizontal Ailerons, Vertical Elevator (Mode II); Throttle (Mode I)
6. Trim Lever, Elevator (Mode II); Throttle Trim (Mode I)
7. Trim Lever, Ailerons
8. Trimmer Panel Cover
9. Power Switch
10. Trim Lever, Rudder
11. Trim Lever, Throttle (Mode II); Elevator Trim (Mode I)
12. Control Stick, Horizontal Rudder, Vertical Throttle (Mode II); Elevator (Mode I)
13. Neck Strap Hook
14. Elevator Dual Rate Switch
15. Throttle Hold Switch
16. Gyro or Gear Switch
17. Pitch Trim Knob
18. Carrying Handle

FIGURE 1

SECTION IV

UNPACKING AND SETTING UP YOUR AIRTRONICS VANGUARD FM 6H RADIO CONTROL SYSTEM

The packaging of your AIRTRONICS Radio Control System was especially designed for the safe transportation and storage of the components. **DO NOT DISCARD THESE CONTAINERS** as they can be used for storage or returning equipment for service.

We recommend the following procedure to familiarize yourself with the components of your system and as preparation for installation in your model:

1. Remove the transmitter from the packing box.
2. Affix the channel identifier (frequency) plaques as stated in the Installation and Guidelines Manual.
3. Charge the receiver and transmitter batteries as stated in the Installation and Guidelines Manual.
4. Switch on the transmitter and note that the movement of the expanded scale voltmeter indicates the unit is operating. The meter reads voltage and is an indication of the state of charge of the internal NiCd battery pack. With a fully charged battery the meter will read in the upper portion of the silver section of the meter face. A reading in the center orange portion indicates a marginally discharged NiCd battery; while a reading in the red portion indicates a battery that is discharged below an acceptable level. Readings below orange, just after a battery charge indicates a defective battery. Either

replace the transmitter battery pack (P/N 95010) or return the unit to AIRTRONICS for service. You should also note the needle deflection, after the transmitter battery has been completely charged. If this reading changes substantially in the future, it may indicate a drop in battery performance, and the radio should be checked at AIRTRONICS. A low voltage audio alarm is also incorporated into the transmitter, which will sound when the voltage drops below 9.5 volts when the transmitter is on.

WARNING: DO NOT ATTEMPT TO USE THE TRANSMITTER, UNLESS THE METER IS READING TOTALLY IN THE SILVER AREA, WITH THE ANTENNA FULLY EXTENDED.

CAUTION: IF NO MOVEMENT IS NOTED ON THE METER WHEN YOU TURN THE TRANSMITTER SWITCH ON, THE BATTERY PACK WITHIN THE TRANSMITTER IS MORE THAN LIKELY DISCHARGED. CHARGE THE BATTERIES AS OUTLINED UNDER SECTION "IV" BATTERY CHARGING, IN THE INSTALLATION AND GUIDELINES MANUAL.

REMEMBER THAT A TRANSMITTER WHOSE PERFORMANCE HAS DROPPED, MAY FAIL TO SEND THE SIGNALS NECESSARY TO ADEQUATELY AND SAFELY CONTROL THE MODEL, RESULTING IN A POSSIBLE CRASH.

- Switch "off" the transmitter, and remove all of the other components from the foam packing box containing your AIRTRONICS VANGUARD FM 6H Radio Control System.
- Figure 2 shows how to connect the components of your system together. Note, the servo and switch harness plugs are inserted in the receiver so that pin #3 is towards the right side of the receiver.

When using any auxiliary equipment or testers, the connections as shown in Figure 3, should be observed. At this point, your objective is to get the system operating on your workbench. Once connected, you must then refer to the corresponding diagram for your system (Figure 4), showing the transmitter control sticks' function.

Take the time to learn the names of all the components you are going to connect, and to identify all the transmitter control stick functions, and names attached to these functions.

NOTE THE FOLLOWING AT THIS POINT:

- It is of no consequence which servo you plug into which function since your aim is simply to learn, and see how the system operates on your bench. The numbered channel outputs are indicated on the receiver case. See Figure 2 for the receiver channel identification.
 - The connectors on your AIRTRONICS Radio System are rugged, but should be handled with care. There are three socket contacts in the servo connector, numbered 1 through 3. The #1 is the signal pin, #2 is negative and #3 (red trace) is positive, (Figure 3). Be sure to insert the plugs into the receiver so that the #3 pin is towards the right side of the receiver.
 - Do not attempt to force the servo plugs into the receiver; properly align each plug and it will move into place with only moderate pressure. The same is true of the plug leading from the receiver battery pack and switch harness.
 - To disconnect battery or servo plugs from the receiver, grasp the plug body and pull out; never disconnect by pulling on the wires.
- Once you have followed the diagrams for connecting the airborne components of your AIRTRONICS VANGUARD FM 6H Radio Control System, and you have studied and understood all of the components, as well as having studied and understood the diagram illustrating the transmitter control stick functions, you are ready to energize the System and study its actual operation.
 - Switch on the transmitter, then switch on the airborne package. The System is now energized. There may be some initial movement in the servos even though you have not moved the transmitter sticks. This is normal. Once they have found a position they will stay there until you move a control on the transmitter.
 - Now follow the diagram indicating the transmitter's control functions, by moving each stick and watching the reaction of the servo or servos. Move the small black trim levers, and note the slight servo movements. Keep

these all centered through the installations of your System in your model. They will be used in actual flight or operation of the model, to adjust servo position slightly . . . a process called "trimming." If the airborne system fails to operate, charge the battery pack as outlined in the Battery Charging Section IV of the Installation and Guidelines Manual.

- Switch off the receiver, then switch off the transmitter. Get used to this sequence: When turning the System on, the proper sequence is to turn on the transmitter, then the receiver.

Adjustments of the functions available on the Trimmer Panel will be addressed in Section V, Operation and Adjustments. A basic transmitter configuration is shown in Figure 5, with trimmers centered, clockwise or counter-clockwise as applicable to indicate their correct position along with correct switch positions.

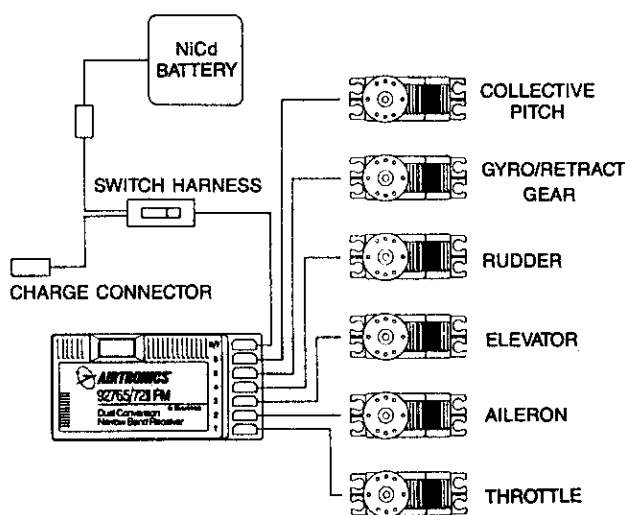
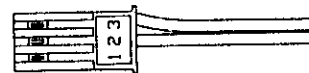

FIGURE 2

- 3 — Battery Positive
2 — Battery Negative
SWITCH HARNESS PLUG



- 3 — Battery Positive
2 — Battery Negative
1 — Control Signal
SERVO PLUG

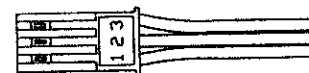
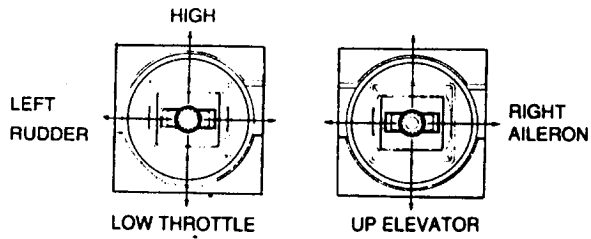
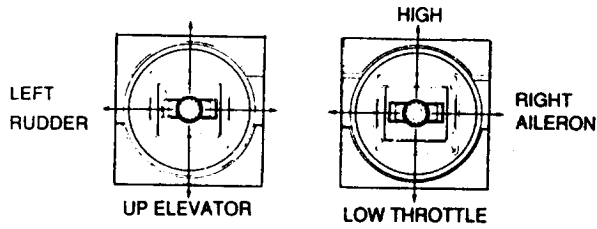

FIGURE 3



MODE II



MODE I

FIGURE 4

BASIC TRANSMITTER TRIMMER PANEL CONFIGURATION

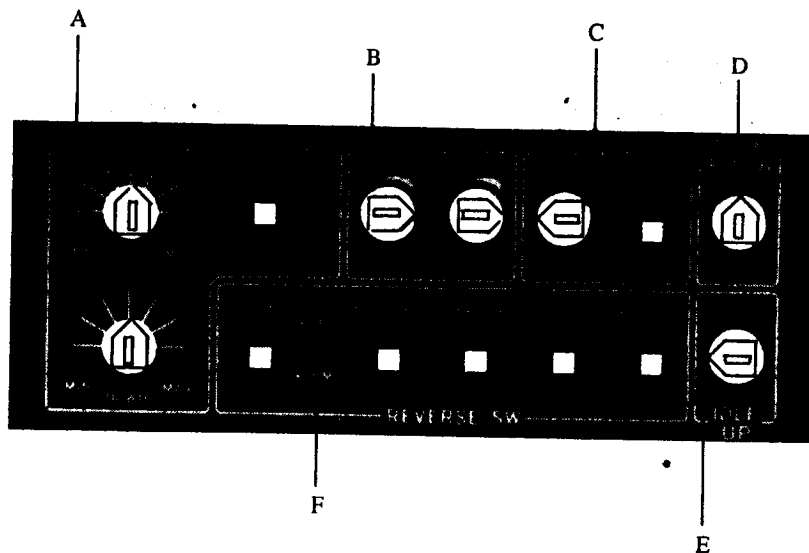

- A. 2 Way Revolution Mixing
- B. Dual Rate Trimmers
- C. Throttle Hold Trimmer
- D. Pitch Curve Trimmer
- E. Idle-Up Trimmer
- F. Servo Reverse Switches

FIGURE 5

SECTION V

OPERATION AND ADJUSTMENTS

FOR SAFE AND SUCCESSFUL OPERATION OF YOUR RADIO CONTROL MODEL, IT IS IMPORTANT TO CAREFULLY FOLLOW THE INSTRUCTIONS BELOW AND OBTAIN TRAINING IN THE OPERATION OF YOUR MODEL FROM A WELL EXPERIENCED INDIVIDUAL.

At this point, having followed all of the instructions, directions and guidelines contained in the earlier sections of this manual, and having completed your model, and installed your VANGUARD FM 6H System, observing the directions and guidelines in the separate manual entitled, FUNDAMENTALS AND GUIDELINES FOR INSTALLATION OF YOUR AIRTRONICS SYSTEM"; we present here general instructions concerning the process of learning to operate and adjust your VANGUARD FM 6H System. Most of these instructions are directed toward those using the System in model helicopters. However, the FM 6H can also be used in its basic configuration in model airplanes. To use it in this manner, it is only necessary to zero, or disable, all of the helicopter-only functions; see Figure 5. Take a few minutes to familiarize yourself with all the features and functions of this advanced radio control system and its many advantages.

It should be re-emphasized that before you make initial use of your completed model, you should have an experienced R/C modeler check your radio installation. We recommend the individual(s) who are "checking out" your model review all our instruction manuals to make certain you have followed all the directions and guidelines, and understand the warnings that have been given. This should be done even if you are obtaining flight training from experienced and competent flyers.

Although helicopters use different control surfaces than airplanes, i.e., the main rotor for pitch and roll instead of the elevator and ailerons, and the tail rotor for yaw instead of the airplanes' rudder; it has become practice in R/C to refer to those helicopter transmitter controls as if they were controlling an airplane. For the purpose of this manual, we are following the habit.

DUAL RATE ADJUSTMENT (D/R)

The VANGUARD FM 6H Transmitter is equipped with Dual Rate functions on ailerons (4) and on the elevator (14), see Figure 1. With the dual rate switch turned "On," the amount of servo movement or throw, to a maximum of 90° of servo rotation, is set with the associated "D/R adjust" trimmers, located under the front panel Figure 5. The use of low rate on these primary flight controls will generally help in smoother flying, since it will reduce the servo throw even when the control sticks are moved to their maximum position. Use a small screwdriver when adjusting the dual rate trimmers on the panel. Be careful not to apply a tremendous amount of pressure to the trimmer, since it should turn easily.

To set the aileron and elevator dual rates, turn on the entire system; i.e., transmitter, receiver and servos. Set the dual rate switches (14) (4) to the "Off" position. Operate the elevator and aileron channel control stick (5) over its full deflection, and observe the corresponding servos; note that you get full servo movement.

Now switch the aileron and elevator dual rate switches to the "On" position and operate the same controls. You should see less servo rotation. If not, the dual rate trimmers on the panel may be set to full travel (no travel reduction). Assuming this is the case, insert a small screwdriver into the associated D/R trimmer slot (Figure 5), and rotate the trimmer counter-clockwise until, with the control stick held to full deflection, some reduction in servo travel is seen. Continued rotation of the D/R trimmer will cause servo travel to be reduced to as little as 25%. Switching the dual rate switch to "Off" will return servo travel to its normal full movement.

You may set the dual rate (D/R) adjustment anywhere within its range, and when the aileron and elevator D/R switches are set to "On," servo travel on that channel is reduced to the pre-set amount. Figure 6 presents the dual rate adjustment limits.

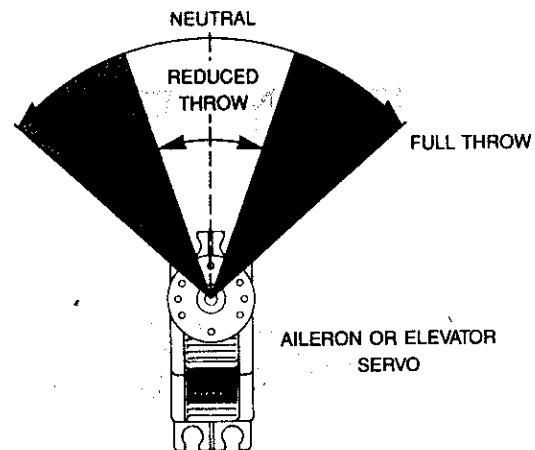

Dual rates are adjustable within the ranges shown using the D/R trimmers under the front panel. Dual rate throws are activated using the Aileron and Elevator D/R switches (4) (14) Figure 1.

• FIGURE 6

WARNING: BE CERTAIN THAT YOU PAY CAREFUL ATTENTION TO THE POSITION OF AILERON/ELEVATOR RATE SWITCHES, ESPECIALLY DURING TAKE OFFS AND LANDINGS. IMPROPER OR UNEXPECTED RATE SWITCH SETTINGS COULD CAUSE INSUFFICIENT CONTROL, RESULTING IN A CRASH AND/OR INJURY TO YOURSELF OR OTHERS.

PLUG-IN CRYSTALS

Your VANGUARD FM 6H transmitter and receiver feature plug-in crystals for ease of manufacture. The FM crystals *should not be changed* by the owner because realignment of the transmitter FM deviation is required following a crystal change. Failure to do this could cause the transmitter signal to be outside of the receivers pass band. This could cause loss of control and a subsequent crash of your model. *Do not change crystals!* If a change of operating channel is desired, return the Vanguard transmitter and receiver to Airtronics for the desired channel change.

CONTROL STICK LENGTH AND TENSION ADJUSTMENT

The length and spring tension of the control sticks (5) and (12) can both be adjusted as required by the individual flyer. Both procedures are simple.

To adjust the spring tension, first remove the battery pack cover by depressing the two latches and unplug the battery pack. Then, remove the four rear cover screws as indicated on the sketch below, Figure 8. The rear cover can now be lifted off. Three of the four screws indicated on the right hand sketch of a Mode II Transmitter will now be visible. They control stick tension as follows: (1) Elevator Mode II; (2) Rudder; (3) Aileron; (4) Elevator Mode I. Adjust the screw in for more tension.

Adjusting the control stick length is even easier. To do so, hold Part B with the fingers and unscrew Part A counter-clockwise to loosen the two pieces. Now move Part A in or out to the desired position, and lock it in place by screwing Part B against it. It is recommended that at least four threads be left inside Part A at its longest length for best mechanical security. Do not over tighten.

SERVO REVERSE

Your VANGUARD FM 6H Transmitter is equipped with servo reversing on five of its six channels. This simplifies the servo installation in your helicopter model since you do not have to be concerned about the movement of the servos

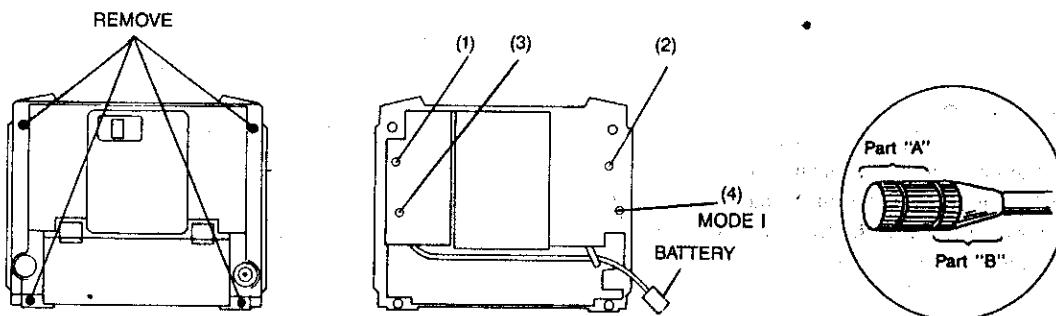
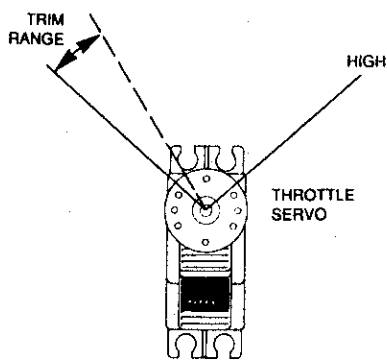

FIGURE 7

in the proper direction, but only in their most effective hookup. After servo installation is complete, simply move the "Reverse-Normal" switches for proper control operation as necessary. None of the other functions will be affected, (See Figure 5).

THROTTLE SERVO ADJUSTMENT

Your VANGUARD FM 6H Transmitter throttle trim located on the control gimbal is only effective at the low throttle position and it does not effect the collective control servo. You should mechanically set the low and high throttle limits in your model with the throttle trim lever (11) in the high position. Your throttle trim can then be used to fine tune the engine idle as well as used for engine cut-off, since it is only effective at the low throttle control stick position.



The transmitter Throttle Trim Lever (11) only functions when the throttle control stick is in the full low position.

FIGURE 8

THROTTLE HOLD

The VANGUARD FM 6H Transmitter incorporates a Throttle Hold function, which does exactly what it says, i.e., it holds the throttle servo at a predetermined setting no matter where the throttle control stick (12) is moved; see Figure 10.

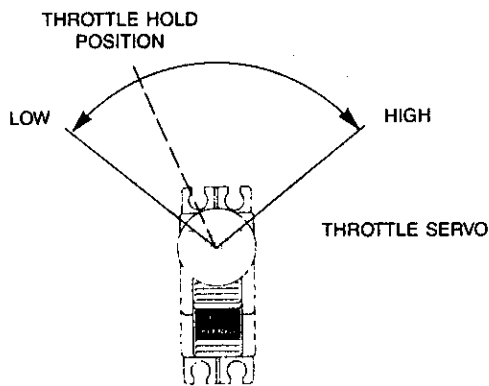

The throttle is held in a predetermined position, as determined by the "Hi-Low" Trimmer under the front panel cover, when the Throttle Hold-Inhibit switch is in the "Hold" position and the Throttle Hold switch (15) is on, regardless of the throttle stick position.

FIGURE 9

On a Mode II transmitter, the left stick controls both the throttle and collective functions; however, when the Throttle Hold function is activated, the throttle stick will only control the collective pitch. Throttle Hold is activated by placing the throttle hold "INHIBIT-HOLD" switch on the trimmer panel in the "Hold" position and the Throttle Hold Switch (15) on the top left of the front panel, Figure 1, to "ON". The engine speed when in the Throttle Hold mode of operation is controlled by the "Low-Hi" throttle hold trimmer, Figure 5. The Throttle Hold feature allows you to hold the engine at a specific throttle setting and still maintain full command of the collective pitch with the throttle control stick. It is recommended that whenever the Throttle Hold feature is not desired, the Throttle Hold "INH-HOLD" switch be maintained in the "INH" position to prevent accidental operation.

The Throttle Hold feature can be used to adjust the engine to a reliable idle when practicing autorotations by adjusting the Throttle Hold "Low-Hi" trimmer to position the throttle servo to the desired point. When the "Throttle Hold" switch (16) is "ON", the throttle trim lever (11) is still available to fine tune engine speed for autorotation practice. This feature allows you to perform auto rotations at a reliable idle setting using mid-range to high throttle trim, and yet enables you to stop the engine for a real autorotation by reducing the trim lever to the full low position.

THROTTLE IDLE-UP

The Idle-Up feature is used to maintain the engine speed at a predetermined point above idle even though the throttle control stick is moved to the low throttle position to produce low collective pitch condition. This is desirable for aerobatics because the engine RPM and rotor speed must be kept high even though the collective pitch is reduced to a low setting. Idle-Up creates some of the effect of an engine low speed governor, and while it does not operate exactly as such

a governor would, it does prevent the engine speed from dropping during aerobatics even when the throttle stick is at the lowest pitch position. We recommend that the "Idle-Up" function be used during these maneuvers.

The operation of the "Idle-Up" function is controlled by the two position Idle-Up switch (3) located on the top right side of the transmitter, and by the "Idle-Up" trimmer located on the trimmer panel. Use the Idle-Up trimmer to set the desired Idle-Up throttle servo position when the Idle-Up switch (3) is in the "ON" position.

Figure 11 illustrates a setting of the Idle-Up function. When Idle-Up is not used, turn the Idle-Up trimmer (Figure 5) fully counter-clockwise.

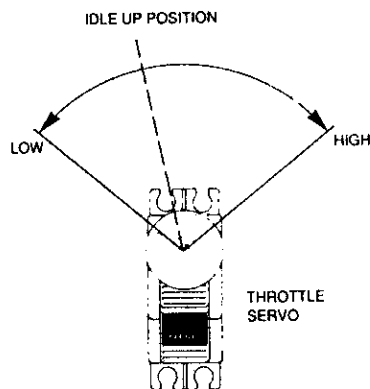

FIGURE 10

USING THE GYRO SYSTEM

Gyro systems for R/C model helicopters and the transmitters they are flown with have to be designed to work with each other in order to make full use of the best features of both. The AIRTRONICS 96252 gyro system is designed to take full advantage of the features of the VANGUARD FM 6H, and vice versa, and therefore are highly recommended for use with each other.

It is recommended that you set up the gyro system on the bench for familiarity and perform the initial adjustments as follows:

1. Connect the gyro system to the VANGUARD FM 6H receiver as indicated in Figure 12. A single 1200 MAH or 700 MAH battery can be used to power both the receiver and the gyro as shown in Figure 13. However, if a separate power source is desired for powering the gyro, the connections should be made as shown in Figure 14.
2. Turn Gain I and Gain II trimmers on the control box fully counter-clockwise (CCW) and turn the switch "ON." The Gyroscope motor should operate.
3. Use the Neutral Adjustment Trimmer on the Gyro Mixer to neutralize the rudder servo.

4. Set your VANGUARD FM 6H Gyro "I" - "II" control switch (16) to the "I" position. Note that movement of the Gyro will not cause any servo response. To activate the gyro, position the Gyro Control switch to the number II position.
5. If you desire to only control Gyro "ON-OFF" operation, leave Gain I Trimmer on the control box fully CCW, and adjust Gain II for the desired control response from the rudder servo when the tail of the helicopter is slewed. If the tail rotor pitch correction is in the incorrect direction, switch the Gyro Output

Reverse Switch on the Gyro Mixer from Normal to Reverse or Vice Versa.

6. If you desire to have two different sensitivity settings for gyro response instead of Gyro On-Off, continue with step 7.
7. Adjust Gain I on the Control Box for the desired "I-II" rudder servo response, when the Transmitter Gyro switch is in the "I" position. The "II" position is then set by Gain Trimmer II as previously stated. Final setting of both trimmers are set according to flight tests.

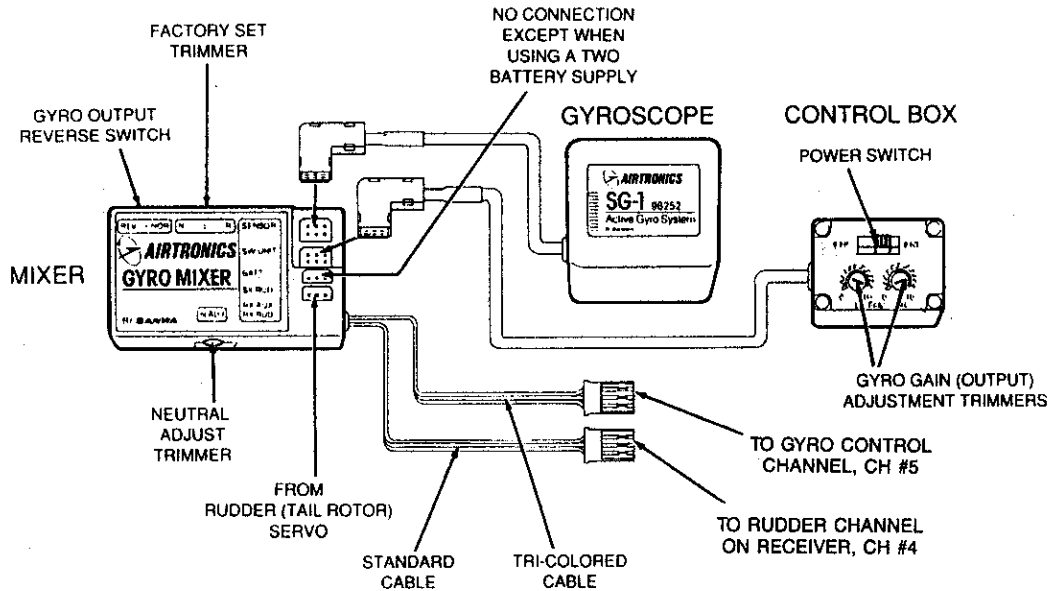

FIGURE 11

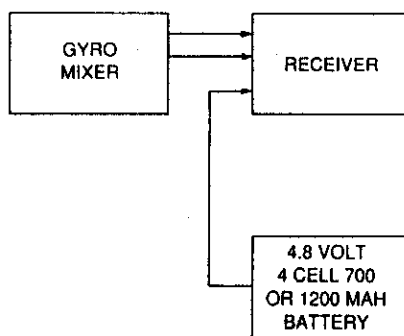

FIGURE 12

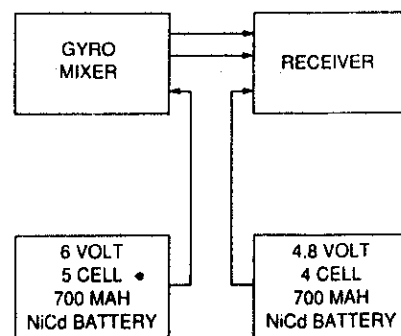

FIGURE 13

Airtronics also offers an economical Integrated Gyro/Rudder servo system, 96253 SG-X, for use with helicopter radios. We also recommend you initially set up the gyro system on the bench for initial tests as we indicated for the 96252 gyro. Adjustments are accomplished as follows:

1. Connect the gyro system to the helicopters receiver as indicated in Figure 14. A single 1200 MAH or 700 MAH battery can be used to power both receiver and the gyro as shown in figure 15. The Gyroscope motor should operate.

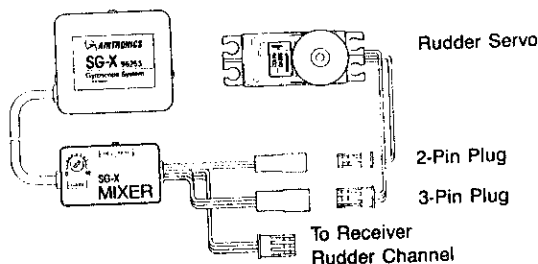

FIGURE 14

2. The Gain control on the Mixer is factory set for optimum control response from the rudder servo when the tail of the helicopter is slewed. If the tail rotor pitch correction is in the incorrect direction, switch the Gyro Output Reverse REV-NOR Switch on the Gyro Mixer from Normal to Reverse or vice versa.
3. Final setting of the Gain Trimmer on the Mixer is determined by flight tests.

Note: Only the rudder servo supplied with the Integrated SG-X Gyro system must be used with this unit since it is an integral part of the unit:

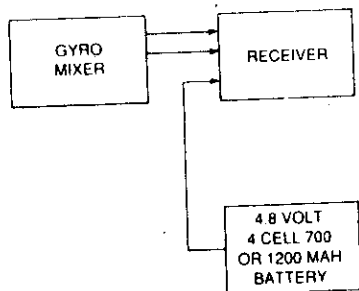

FIGURE 15

If, on the other hand, the nose seems to turn to the right, rotate the same knob a small amount to the left. Make small changes and repeat the "Climb Test". Now, with the helicopter in descending flight, we will make the same adjustment to the "DOWN" trimmer. If the nose swings to the left, turn the trimmer setting slightly to the left. Conversely, if the nose turns to the right, turn it right. Easy does it!

NOTE: Always refer to the helicopter nose, not the tail, since you always fly the nose.

Please pay particular attention to the fact that for ascending, if the helicopter's main rotor rotates to the left, (counter-clockwise), each of the corrections described above is made in the opposite direction. That is, for ascending flight, if the nose swings right, correct left, etc.

RUDDER MIXING

As power and/or collective are applied to the main rotor of the helicopter, a reverse torque is generated which causes the fuselage to rotate in the opposite direction. To counteract this torque, a certain amount of opposite rudder control must be applied as the throttle/collective is advanced. The VANGUARD FM 6H does this for you automatically. There are no external controls for rudder mixing, only those "Set and Forget" trimmers on the Trimmer Panel (5) and a switch which is used to set the direction of the control to be applied or to disable the function.

To use the VANGUARD FM 6H Rudder Mixing Function:

1. First, viewing the helicopter from above, set "L-INH-R" switch, Figure 5, on the trimmer panel in the same direction as the rotation of the rotor. If the main rotor turns to the right (clockwise) set the switch to "R". If the main rotor turns to the left (counter-clockwise), it should be set on "L".
2. Set the "REV MIX" adjustment trimmers as follows: "UP" or ascent trimmer to 70% travel from Min to Max; the "DOWN" or descent trimmer to 50% travel (straight up). These are the beginning settings.
3. Bring the helicopter to a hover. Remember that "UP" adjustments will only be affected by the upper portion of stick travel from the hover position and "DOWN" adjustments by the lower portion of stick travel from the hover position.
4. Final setting of these controls is determined in the following manner: With the helicopter in a hover, add power/collective to climb and watch the movement of the nose. Based on helicopters whose main rotor turns to the right (clockwise), if the nose seems to turn to the left, turn the "Up" knob a slight amount to the right.

PITCH CURVE ADJUSTMENT

With variable collective pitch helicopters it is desirable to match the engines torque curve and the pitch curve. In essence, the modeler has the capability to adjust (or limit) the maximum and minimum angle of incidence, i.e., collective pitch of the main rotor blades.

The high pitch trimmer is located on the panel underneath the panel cover. The high-point is the setting at which the pitch differential starts, and it can be set as desired from 60% of the throttle stick up to 100% of the full-high position as shown in Figure 16. The high-pitch level, based on this point, can be set from 10 to 100%. The pitch knob (17) located on the upper left side of the transmitter can be used to move the entire pitch curve up and down without adjusting the pitch links of the rotor head. The pitch trim knob will move the servo approximately 20 degrees. Figure 17 shows the corresponding overall pitch curve change.

NOTE: Whenever you use Throttle-Hold, the pitch curve is automatically switched into linear, i.e., maximum pitch. We recommend you set your helicopter pitch linkage to the maximum pitch required for autorotation operation and use the pitch knob to set pitch for normal flight.

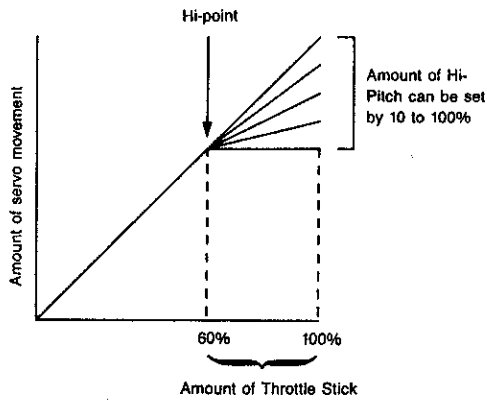

Movement of Pitch Curve

FIGURE 16

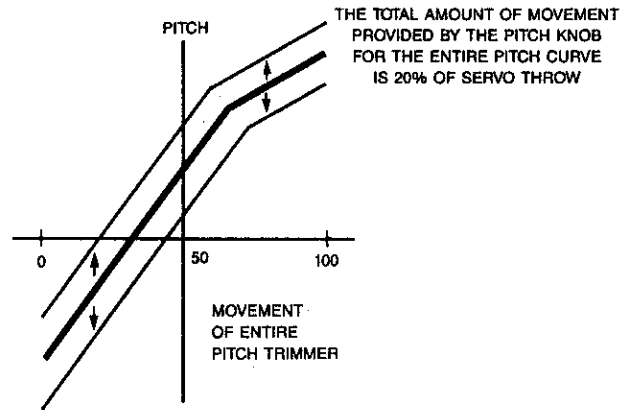

OVERALL PITCH TRIM CONTROL OPERATION

FIGURE 17

ASSEMBLY OF CHANNEL IDENTIFIER

Your AIRTRONICS channel identification plaques and flag are assembled to the holder as indicated in Figure 18. Note that the plaque holder is installed on the antenna so that it will not slide down the antenna.

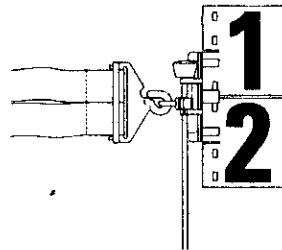

FIGURE 18

FOR WARRANTY INFORMATION, PLEASE SEE SECTION VII OF THE INSTALLATION FUNDAMENTALS AND GUIDELINES MANUAL.