

AIRTRONICS[®] INC

VANGUARD FM 4/6 CHANNEL

RADIO CONTROL INSTRUCTION MANUAL



VANGUARD FM 4/6 CHANNEL

FOR THE SAFETY OF OTHERS:

TABLE OF CONTENTS

SECTION I	Safety First for Yourself and Others
SECTION II	Federal Licensing Requirements and Special Operating Standards for Model Airplanes
SECTION III	System Features
SECTION IV	Unpacking and setting up your AIRTRONICS VANGUARD Radio Control System
SECTION V	Operation and Adjustments

NOTE: FOR BATTERY CHARGING INFORMATION AND INSTRUCTIONS ON LEARNING TO USE YOUR AIRTRONICS RADIO CONTROL SYSTEM, PLEASE SEE THE AIRTRONICS INSTALLATION FUNDAMENTALS AND GUIDELINES MANUAL.

THANK YOU FOR SELECTING AIRTRONICS

We appreciate your purchase of this new AIRTRONICS VANGUARD RADIO CONTROL SYSTEM.

These instructions are intended to acquaint you with the many unique features of this modern, state-of-the-art equipment. Please read them carefully so that you may obtain maximum success and enjoyment from its operation.

We ask that you pay particular attention to the design of the transmitter.

Notice that it has been human engineered for the most natural and precise control of your choice of flying models.

Be certain to read all of the material in this manual, as well as that in the Fundamentals and Guidelines Manual.

SECTION I

SAFETY FIRST FOR YOURSELF, FOR OTHERS AND FOR YOUR EQUIPMENT

"SAFETY FIRST" is more than just a slogan when operating radio controlled models. Thus, we urge, especially with respect to radio controlled aircraft that:

FOR YOUR SAFETY:

Recognize that radio controlled models are not harmless toys and can be dangerous missiles if carelessly or improperly flown. You are responsible because the reliability and safe operation of the radio equipment is largely dependent upon its proper installation and utilization.

THEREFORE, INSTALL YOUR RADIO CONTROL SYSTEM CORRECTLY AND BE CERTAIN YOU CAN FLY WELL ENOUGH TO CONTROL YOUR AIRCRAFT UNDER ALL CONDITIONS.

Remember that you are responsible for the safety of all spectators and in fact, everyone that may foreseeably be injured by your model.

DO NOT FLY where your model could injure any person or property.

DO NOT FLY over the heads of spectators or persons in the area of your flying field. **THIS INCLUDES** taking off, actual flight and landing. **KEEP EVERYONE**, except experienced and knowledgeable persons who are assisting you in flying, away from your model even when it is on the ground and you are preparing to fly.

DO NOT FLY unless and until you have an experienced instructor who has completely **CHECKED OUT THE MODEL AND WILL FLY THE MODEL FOR YOU AND WITH YOU . . . UNTIL YOU HAVE LEARNED TO FLY COMPETENTLY BY YOURSELF.**

Flying is a real skill that demands patience, practice and caution. **DO NOT EXPERIMENT** or run **RISKS**. **KNOW** that you can fly safely before you fly alone. The real pleasures and satisfactions come from flying or operating your model with **SAFETY** and competence always in mind.

DO NOT FLY in adverse weather conditions. Strong winds, for example, may cause loss of control of your aircraft and cause injury or damage to you or to others.

AT THE FIELD . . .

DO NOT FLY unless your frequency is "clear." The transmitting signal channel (frequency) is shown on the transmitter and **YOU MUST NOT** turn on your transmitter when someone is flying or operating their model on that same frequency.

WARNING: IF YOU DELIBERATELY OR ACCIDENTALLY TURN ON YOUR TRANSMITTER WHILE ANOTHER MODEL IS FLYING OR IN OPERATION, THAT MODEL WILL GO OUT OF CONTROL. The same will happen to yours, so observe "clearing" the frequency: Only one person using a given frequency at a time. **DO USE CHANNEL IDENTIFIER (FREQUENCY) FLAGS** for the frequency your system uses and attach the appropriate flags to your transmitter antenna. **DO OBSERVE** all of the rules of the flying or operating site.

The Channels and frequencies associated with them are as follows:

• <u>72 MHz Band (Aircraft Only)</u>	
<u>CHANNEL NUMBERS</u>	<u>FREQUENCY (MHz)</u>
12	72.030
38	72.550
40	72.590
42	72.630
44	72.670
46	72.170
48	72.750
50	72.790
52	72.830
54	72.870
56	72.910

ADDITIONAL
CHANNELS 14 THROUGH 34 WERE ADDED
AS OF JANUARY 1, 1988

<u>CHANNEL NUMBER</u>	<u>FREQUENCY (MHz)</u>
14	72.070
16	72.110
18	72.150
20	72.190
22	72.230
24	72.270
26	72.310
28	72.350
30	72.390
32	72.430
34	72.470

NOTE: For the period January 1, 1988 to January 1, 1991, only Narrow band transmitters will be permitted to operate on Channels 12 through 34 inclusive. Channel number plaques are used to identify a specific channel.

WARNING: The frequencies allocated for Model Radio Control use designated above are exclusive; however, they are in close proximity to other types of radio use in certain areas. Before operating your Model check with the Federal Communications Commission (FCC) Regional Office in your area to determine whether there is a potential danger of interference from other radio users. "Outside" radio interference may cause you to lose control of your model, possibly causing injury to yourself, to others, or property damage.

SO REMEMBER:

1. **DO NOT OPERATE** your transmitter at the field until you are certain your frequency is "clear".
2. **DISPLAY** your frequency flag colors and/or channel identification plaques on the antenna of your transmitter.
3. **REMEMBER** that channel identifier plaques do not usually state the frequency on them and sometimes the wind streamer colors are hard to distinguish. Ask and be certain. If you have an eyesight limitation or defect such as color blindness for example, double check to be sure of channel plaque designations.
4. Turn your transmitter on only when you are sure no one else is using your frequency.
5. **WARNING:** Your model will go out of control and may do serious injury or damage if someone else turns on a transmitter on your frequency while you are operating your model.
6. Respect all the rules of the flying field or site.
7. At any time during the operation of your model, should you sense, feel or observe any erratic operation or abnormality, end your flight as quickly and as safely as possible. **DO NOT** operate again until you are certain the problem has been corrected. **TAKE NO CHANCES.**

ADDITIONAL WARNING:

Radio controlled models are generally attractive, exciting and inviting in looks and performance. Therefore, realize that young persons, children and inexperienced adults may come within the operating range of the model, so that they may try to operate the equipment without understanding the dangers to that person or others. It is your responsibility to guard against unskilled and unknowing hands for their protection as well as for the safety of your equipment and model.

The key to R/C pleasure is the proper use of your System and all of the other model components. If you fail to follow instructions, heed the warnings given, misuse or abuse the system through improper operation or installation, the consequences will damage your system and may also mean injury to yourself, other people or property of others.

AS TO YOUR EQUIPMENT:

The care you give to your radio control equipment, and its correct installation and operation, are the factors that spell either safe, successful flying or injury, damage, destruction and loss.

ACADEMY OF MODEL AERONAUTICS (AMA)

The Academy of Model Aeronautics is the leading national organization made up of aircraft modeling people with headquarters near Washington, D.C. Its address is 1810 Samuel Morse Drive, Reston, VA 22090, and we urge you to examine the benefits of membership including liability protection in the event of certain injuries. The Academy has adopted simple and sane rules, a few which are pertinent for radio controlled flight as the **OFFICIAL AMA SAFETY CODE**; abide by these rules for your protection, the protection of others and other equipment. Excerpts are as follows:

1. I will not fly my model aircraft in competition or in the presence of spectators until it has been proven to be air-worthy by having been previously successfully flight tested.
2. I will not fly my model higher than approximately 400 feet within 3 miles of an airport without notifying the airport operator. I will give right of way to and avoid flying in the proximity of full scale aircraft. When necessary, an observer shall be utilized to supervise flying to avoid having models fly in the proximity of full scale aircraft.
3. Where established, I will abide by the safety rules for the flying site I use, and I will not willfully and deliberately fly my models in a careless and/or dangerous manner.
4. I will have completed a successful radio equipment ground range check before the first flight of a new or repaired model.
5. I will not fly my model aircraft in the presence of spectators until I become a qualified flyer, unless assisted by an experienced helper.
6. I will perform my initial turn after takeoff away from the pit, spectator parking areas, and I will not thereafter fly over pit or spectator areas, unless beyond my control.
7. I will operate my model using only radio control frequencies currently allowed by the FCC. (Only properly licensed amateurs are authorized to operate equipment on amateur band frequencies.)

NOTE: These basic safety precautions are for your safety, the safety of others, and of your equipment. Consider carefully all of what has been stated and obey all precautions as well as those appropriate to your particular use. Good common sense must also be used at all times in the operation of your equipment.

AIRTRONICS VANGUARD FM 4/6 CHANNEL

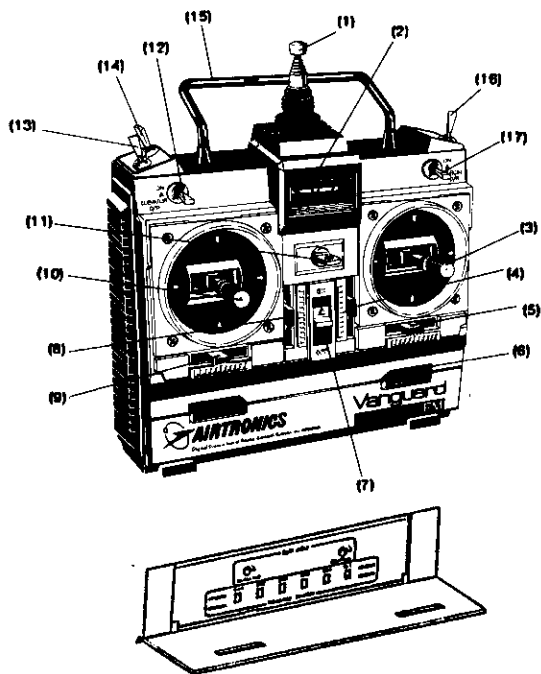

FIGURE 1

TRANSMITTER FEATURES AND FUNCTIONS

The AIRTRONICS VANGUARD Radio Control Systems are primarily intended for the flying of fixed wing model aircraft.

1. Retractable antenna
2. Expanded Scale Voltmeter (ESV)
3. Control stick, horizontal-aileron, vertical-elevator (Mode II); throttle (Mode I)
4. Trim lever, elevator (Mode II); throttle trim (Mode I)
5. Trim lever, ailerons
6. Trimmer cover
7. Power switch
8. Trim lever, throttle (Mode II); elevator trim (Mode I)
9. Trim lever, rudder
10. Control stick, horizontal-rudder, vertical-throttle (Mode II); elevator (Mode I)
11. Neck strap connecting hook
12. Elevator dual rate switch (6 CH only)
13. Retract switch (6 CH only)
14. Trainer switch
15. Carrying handle
16. Three position auxiliary channel flap switch (6 CH only)
17. Aileron dual rate switch (6 CH only)

SECTION II

FEDERAL LICENSING REQUIREMENTS AND SPECIAL OPERATING STANDARDS FOR MODEL AIRPLANES

The Federal Communications Commission no longer requires a license to operate an R/C model transmitter.

However, the Federal Aviation Administration has announced guidelines for operation of model aircraft. We are reprinting those guidelines here and encourage your study and cooperation.

1. Purpose: This advisory circular outlines safety standards for operators of model aircraft and encourages voluntary compliance with these standards.
2. Background: Attention has been drawn to the increase in model aircraft operations, and the need for added caution in the case of free-flight and radio controlled types to avoid creating a noise nuisance or a potential hazard to full-scale aircraft and persons and property on the surface.
3. Operating Standards: Modelers, generally, are concerned about safety and do exercise good judgment when flying model aircraft. However, in the interest of avoiding undue criticism from affected communities and airspace users, COMPLIANCE WITH THE FOLLOWING STANDARDS IS ENCOURAGED BY OPERATORS OF RADIO CONTROLLED AND FREE-FLIGHT MODELS.
 - a. Exercise vigilance for full-scale aircraft (get other people to help if possible) so as not to create a collision hazard.
 - b. Select an operating site at a sufficient distance from populated areas to avoid creating a noise problem or a potential hazard.
 - c. Do not fly higher than 400 feet above the surface.
 - d. Do not operate closer than three miles from the boundary of an airport unless permitted to do so by the appropriate air traffic control facility in the case of an airport for which a control zone has been designated, or by the airport manager in the case of other airports.
 - e. Do not hesitate to ask for assistance in complying with these guidelines at the airport traffic control tower, or air route center nearest the site of the proposed operations.

Director, Air Traffic Service
Federal Aviation Administration
Washington DC.

Under SAFETY, we encouraged your participation in the Academy of Model Aeronautics as a member. Many flying fields require that you be a member of the AMA before they will allow you to use their field. They want to know that all pilots are knowledgeable concerning the AMA SAFETY CODE and through membership have the liability insurance.

SECTION III

SYSTEM FEATURES

TRANSMITTER

- * High Power (500 mw) internal RF Module
- * Advanced Gimbal Design with control stick length and tension adjustment

SYSTEM FEATURES (CONTINUED)

TRANSMITTER (Cont'd)

- * Finely ratcheted trim controls for accurate adjustment
- * Expanded Scale Voltmeter (ESV)
- * Servo reversing available on all primary channels
- * Attractive satin chrome, and black plastic case with internally collapsible ten section antenna
- * Adjustable dual rates for elevator and aileron (6 CH only)
- * Training system compatible with Championship, SR XL, and other Vanguard units
- * Internal Plug-in NiCd transmitter battery
- * Switched auxiliary function (6 CH only)

RECEIVER

Dual conversion 6 channel FM narrow baud receiver that meets AMA guidelines for operation at 20 kHz channel spacing.

SERVOS

The VANGUARD 4 and 6 channel units are available with standard AIRTRONICS servos.

SECTION IV

UNPACKING AND SETTING UP YOUR AIRTRONICS VANGUARD FM RADIO CONTROL SYSTEM

The packaging of your AIRTRONICS Radio Control System was especially designed for the safe transportation and storage of the components. DO NOT DISCARD THESE CONTAINERS as they can be used for storage or returning equipment for repair.

We recommend the following procedure to familiarize yourself with the components of your system and as preparation for installation in your model:

1. Remove the transmitter from the packing box.
2. Affix frequency channel identifier plaques to the transmitter.
3. Charge the receiver and transmitter batteries as stated in the Installation and Guidelines Manual.
4. Switch on the transmitter and note the movement of the meter indicating the unit is operating. The meter is an expanded scale voltmeter which indicates the state of charge of the internal NiCd battery pack. The meter should read in the upper portion of the silver screen of the meter face. A reading in the center orange portion indicates a marginally discharged NiCd battery; while a reading in the red portion indicates a battery that is discharged below an acceptable level. Readings below orange just after a battery charge are indication of defective cells. You should also note where the needle moves to after the transmitter battery has been completely charged. If this reading changes substantially in the future, it may indicate a drop off in battery performance and the ratio should be checked at AIRTRONICS.

WARNING: Do not attempt to use the transmitter unless the meter is reading totally in the silver area.

CAUTION: IF NO MOVEMENT IS NOTED ON THE METER WHEN YOU TURN THE TRANSMITTER SWITCH ON, THE BATTERY PACK WITHIN THE TRANSMITTER IS MORE THAN LIKELY DISCHARGED. CHARGE THE BATTERIES AS OUTLINED UNDER SECTION IV BATTERY CHARGING, IN THE INSTALLATION AND GUIDELINES MANUAL.

REMEMBER THAT A TRANSMITTER WHOSE PERFORMANCE HAS DROPPED MAY FAIL TO SEND THE SIGNALS NECESSARY TO ADEQUATELY AND SAFELY CONTROL THE MODEL RESULTING IN A POSSIBLE CRASH.

5. Switch "off" the transmitter and remove all of the other components from the foam packing box containing your AIRTRONICS VANGUARD FM Radio Control System.
6. Figure 2 shows how to connect the components of your system together. Note the servo and switch harness plugs are inserted in the receiver so that pin #3 is towards the bottom side of the receiver. At this point, your objective is to get the system operating on your workbench. Once connected, you must then refer to the corresponding diagram for your system (Figure 3), showing the transmitter control sticks' function.

TAKE THE TIME TO LEARN THE NAMES OF ALL COMPONENTS YOU ARE GOING TO CONNECT AND TO IDENTIFY ALL OF THE TRANSMITTER CONTROL STICKS' FUNCTIONS AND NAMES ATTACHED TO THOSE FUNCTIONS.

NOTE THE FOLLOWING AT THIS POINT:

- a. It is of no consequence at this point which servo you plug into which function since your aim is simply to learn and see how the system operates on your bench. The correct channel outputs are indicated on the receiver case.

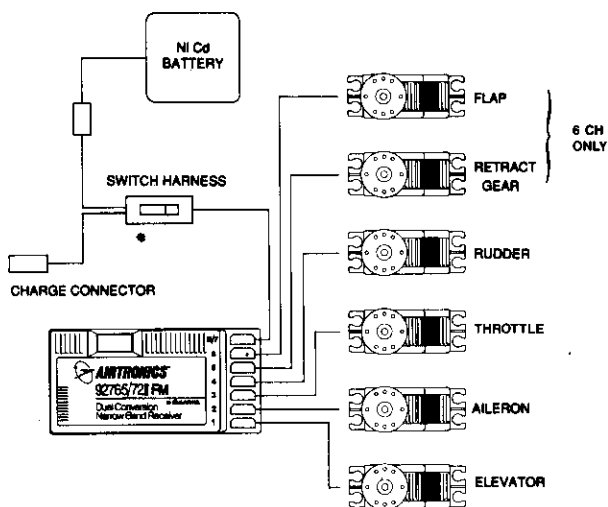

FIGURE 2

SECTION V

OPERATION AND ADJUSTMENTS

FOR SAFE AND SUCCESSFUL OPERATION OF YOUR RADIO CONTROL MODEL, IT IS IMPORTANT TO CAREFULLY FOLLOW THE INSTRUCTIONS BELOW AND OBTAIN TRAINING IN THE OPERATION OF YOUR MODEL FROM A WELL EXPERIENCED INDIVIDUAL.

At this point, having followed all of the instructions, directions and guidelines contained in the earlier sections of this manual and having completed your model and installed your VANGUARD system observing the directions and guidelines contained in the separate manual entitled "FUNDAMENTALS AND GUIDELINES FOR INSTALLATION OF YOUR AIRTRONICS SYSTEM", we present here general instructions concerning the process of learning to use your VANGUARD System. Most of what is stated is directed toward those using the System in a powered model aircraft. However it is equally applicable to sailplanes.

It should be re-emphasized that before you make initial use of your completed model, you should have one or more persons who are thoroughly experienced in the field of radio controlled modeling completely go over the model prior to your use to make certain you have properly installed your VANGUARD System and followed all of the directions given in this manual as well as the Installation Manual. We recommend that the individual(s) who are "checking out" your model be shown these two manuals and that you and they review all of the materials contained in them to make certain that you have followed all directions and guidelines and understand the warnings that have been given. This should be done even if you are obtaining flight training from experienced and competent flyers.

SERVO REVERSING:

The VANGUARD FM transmitters include servo reversing on all channels. This feature makes it possible to select the direction of servo rotation of the channels. Consequently, servo installation is greatly simplified and the direction of the servo rotation becomes unimportant. The servo reversing switches are located under the panel on the front of the transmitter.

DUAL RATE ADJUSTMENT (D/R):

The VANGUARD 6 Channel Transmitter is equipped with Dual Rate functions on ailerons (17) and elevator (12) channels (see Figure 1). The amount of normal control action to a maximum 90° of servo rotation is set with the associated "D/R" adj. trimmers on the panel. The use of low rate on these primary flight controls will generally help in flying smoother maneuvers, since it will reduce the servo throw even when the control sticks are moved to their maximum position. Use a small screwdriver when adjusting the dual rate trimmers on the panel. Be careful not to apply a tremendous amount of pressure to the trimmer since it should turn easily.

To set the dual rates, turn on the entire system; transmitter, receiver and servos. Set the dual rate switches (17) (12) to the

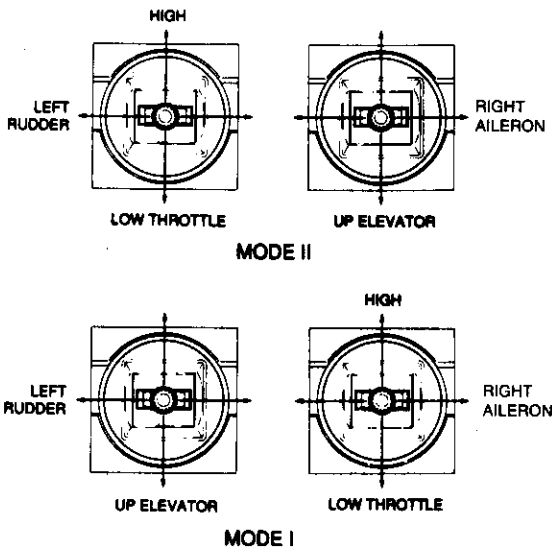

FIGURE 3

- b. The connectors on your AIRTRONICS Radio Control System are rugged but should be handled with care. There are three socket contacts in the servo connector, numbered 1 through 3. The #1 is the signal pin, #2 is negative and #3 is positive. Be sure to insert the plugs into the receiver so that the #3 pin is to the outer edge of the receiver.
- c. Do not attempt to force the servo plugs into the receiver; properly align each plug and it will move into place. The same is true of the plug leading from the receiver-battery pack and switch harness.
7. Once you have followed the diagrams for connected the airborne components of your AIRTRONICS VANGUARD FM Radio Control System and you have studied and understood all of the components as well as having studied and understood the diagram illustrating the transmitter control stick functions, you are ready to energize the System and study its actual operation.
8. Switch on the transmitter, then switch on the airborne package. The System is now energized. There may be some initial movement in the servos even though you have not moved the transmitter sticks. **THIS IS NORMAL.** Once they have found a position, they will stay there.
9. Now follow the diagram indicating the transmitter's control functions by moving each stick and watching the reaction of the servo or servos. Move the small black trim levers and note the slight servo movements. Keep these all centered through the installation of your System in your model. They will be used in actual flight or operation of the model to adjust servo position slightly . . . a process called "trimming". If the airborne system fails to operate, charge the battery pack as outlined in the Battery Charging Section of Installation and Guidelines.
10. Switch off the receiver, then switch off the transmitter. **GET USED TO THIS SEQUENCE: When turning the System OFF, TURN THE RECEIVER OFF FIRST, THEN THE TRANSMITTER.** When turning the System ON, the proper sequence is to **TURN ON THE TRANSMITTER THEN THE RECEIVER.**

MASTER/TRAINER SYSTEM:

"off" position. Operate the elevator and aileron channel control stick over its full deflection and observe the corresponding servos, note that you get full servo movement.

Now switch the dual rates to the "on" position and operate the same controls. You should see less servo rotation. If not, the dual rate trimmer on the panel may be set to full travel (no travel reduction). Assuming this is the case, insert a small screwdriver into the associated D/R trimmer slot and rotate the control until, with the control stick held to full deflection, some reduction in servo travel is seen. Continued rotation of the D/R trimmer will cause servo travel to be reduced as much as 90%. Operating the dual rate switches to off will return servo travel to its normal full movement.

You may set the reduced travel trimmer adjustment anywhere within its range, and when the associated D/R switch is set to "ON", servo travel on that channel is reduced to the pre-set amount.

WARNING: Be certain that you pay careful attention to the position of rate switches, especially during take offs and landings. Improper or unexpected rate switch settings could prevent sufficient control, resulting in a crash and/or injury to yourself or others.

PLUG-IN CRYSTALS:

Your VANGUARD FM transmitter and receiver feature plug-in crystals for ease of manufacture. The FM crystals *should not be changed* by the owner because realignment of the transmitter FM deviation is required following a crystal change. Failure to do this could cause the transmitter signal to be outside of the receivers pass band. This could cause loss of control and a subsequent crash of your model. Do not change crystals! If a change of operating channel is desired, return the Vanguard transmitter and receiver to Airtronics for the desired channel change.

CONTROL STICK LENGTH AND TENSION ADJUSTMENT:

The length and spring tension of the control sticks can both be adjusted as required by the individual flyer. Both procedures are simple.

To the spring tension, first remove the four rear cover screws as indicated on the sketch below (Figure 4). The rear cover can now be lifted off. Three of the four screws indicated on the right hand sketch of a Mode II transmitter are visible. The control stick tension as follows: (1) Elevator Mode II; (2) Rudder; (3) Aileron; (4) Elevator Mode I. Adjust the screw in for more tension.

Adjusting the control stick length is even easier. To do so, hold Part B with the fingers and unscrew Part A counter-clockwise to loosen the two pieces. Now screw Part A in or out to the desired position, and lock it in place by screwing Part B against it. It is recommended that at least four threads be left inside Part A at its longest length for best results.

The VANGUARD FM transmitters have a Master/Trainer (M/T) capability. This allows you to connect a Vanguard transmitter to another like transmitter either FM or AM, or to XL, SR and Championship series units, by use of the Airtronics Trainer System Cable P/N 97100. The expert-level flyer modeler can therefore assist the beginner in learning how to fly.

To use the Master/Trainer capability, plug the trainer system cable into both transmitters. The transmitter that is designated as the Master must match the receiver in use. For the following instructions, the Master transmitter is designated as #1 and the student transmitter will be referred to as #2.

Turn on #1 and the models' receiver switch. Note the position of the control surfaces on the aircraft. The #2 transmitter switch must be in the "off" position, since its encoder receives its power from the #1 transmitter. Push and hold "ON" the trainer switch (14) on transmitter #1. Transmitter #2 now has control of the model. Move the control sticks on the #2 transmitter to insure that the model controls move in the proper direction. You can now check the neutrals of transmitter #2 to insure they correspond to master transmitter #1. Turn the Master/Trainer switch on transmitter #1 "ON" and "OFF" while observing the position of the models control surfaces. Adjust the neutrals of the students #2 transmitter until the models control surfaces no longer change position when turning the #1 Master/Trainer switch "ON" and "OFF". You are now ready for flight.

CAUTION: Remember that transmitter #2 power switch must be in the "off" position.

IT IS IMPERATIVE THAT ONLY AN EXPERIENCED PILOT HELP WITH THE TRAINING OF THE STUDENT ON TRANSMITTER #2.

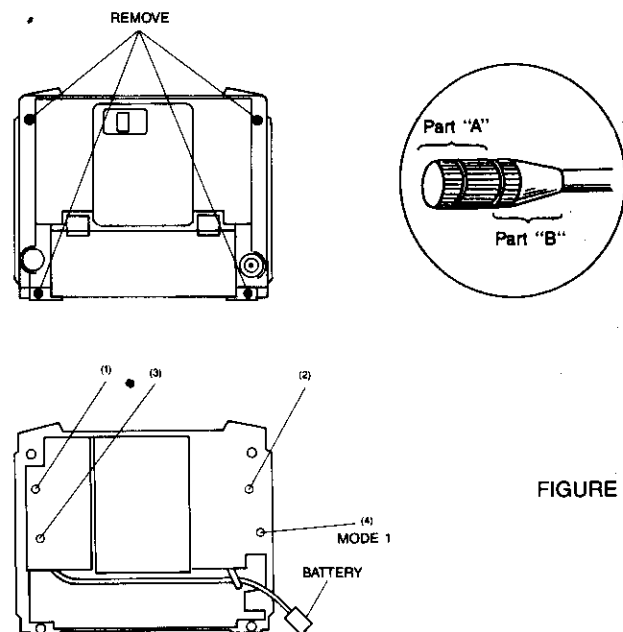

FIGURE 4

ASSEMBLY OF CHANNEL IDENTIFIER:

Your Airtronics channel identification plaques and flag are assembled to the holder as indicated in Figure 5. Note that the plaque holder is installed on the antenna so that it will not slide down the antenna.

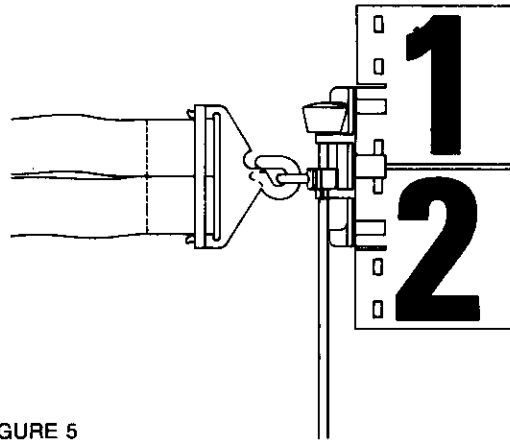

FIGURE 5

FOR WARRANTY INFORMATION, PLEASE SEE SECTION VII OF THE INSTALLATION FUNDAMENTALS AND GUIDELINES MANUAL.



11 Autry, Irvine, California 92718

(714) 830-8769