

92124 2.4GHz FHSS-1 RX500 5-Channel Full-Range Receiver Operating Instructions



Use this receiver with your Airtronics FHSS-1 or FHSS-3 2.4GHz aircraft transmitter, such as the RDS8000 or the SD-10G.

Due to differences in the implementation of 2.4GHz technology among different manufacturers, this receiver is compatible with Airtronics 2.4GHz aircraft transmitters only.

Model: 92124 (RX500)
 Frequency/Modulation: 2.4GHz/FHSS-1
 Input Voltage: 4.8v~6.0v Nominal
 Weight: .34oz (9.7gr) with Case and Antenna Wires
 Weight: .20oz (5.7gr) without Case
 Dimensions: 1.87 x 0.91 x 0.51in (47.5 x 23.0 x 13.0mm)
 Fail Safe Support: Yes (CH 1~CH 4)

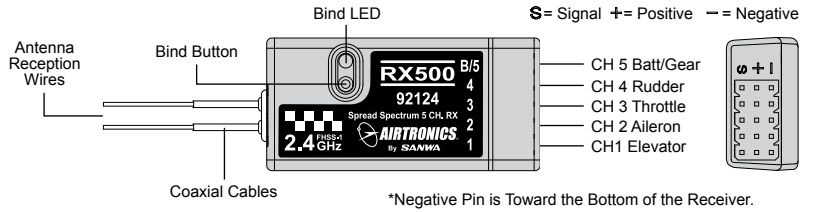

! This receiver operates on the 2.4GHz frequency band. The 2.4GHz connection is determined by the transmitter and receiver pair. Unlike ordinary crystal-based systems, your model can be used without frequency control.

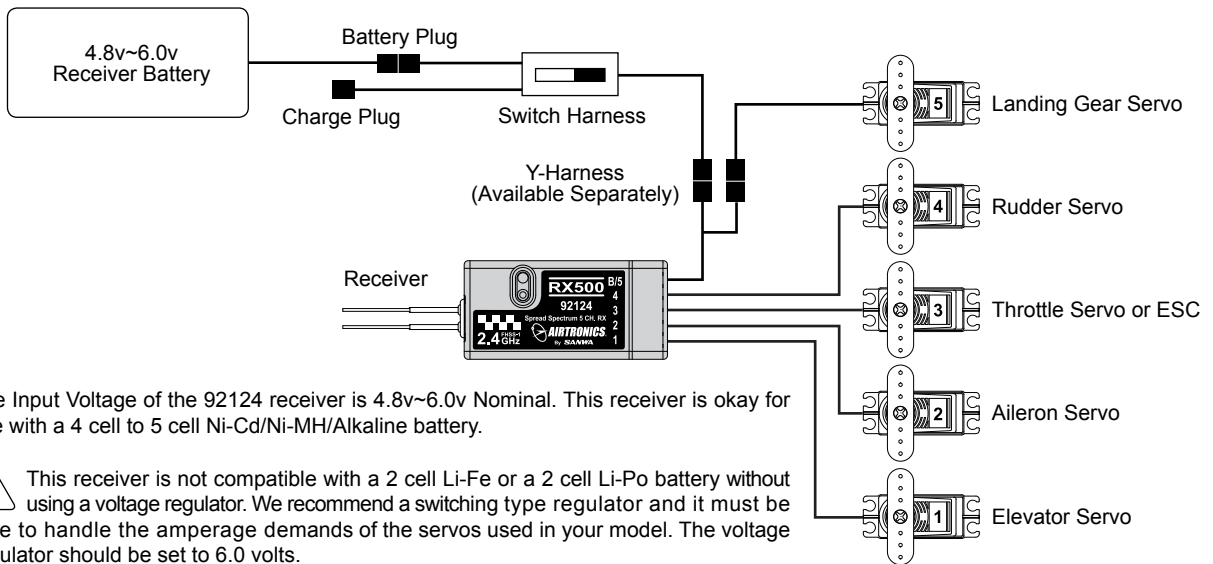

The Input Voltage of the 92124 receiver is 4.8v~6.0v Nominal. This receiver is okay for use with a 4 cell to 5 cell Ni-Cd/Ni-MH/Alkaline battery.

! This receiver is not compatible with a 2 cell Li-Fe or a 2 cell Li-Po battery without using a voltage regulator. We recommend a switching type regulator and it must be able to handle the amperage demands of the servos used in your model. The voltage regulator should be set to 6.0 volts.

! To power the receiver with a servo plugged into channel slot 5, you will need to purchase an Airtronics Y-Harness P/N 477021 (available separately). Plug the Y-Harness into channel slot 5, then plug the servo into one side of the Y-Harness and the switch harness into the other side of the Y-Harness. If you will not be using a servo plugged into channel slot 5, a Y-Harness is not necessary. Simply plug the switch harness into channel slot 5.

2.4GHz FREQUENCY BAND PRECAUTIONS

- The 2.4GHz frequency band may be used by other devices, or other devices in the immediate area may cause interference on the same frequency band. Always before use, conduct a bench test to ensure that the servos operate properly. Also, conduct a range test at the area of operation to ensure that the radio control system has complete control of the model at the farthest reaches of the operational area.
- The response speed of the receiver can be affected if used where multiple 2.4GHz radio control systems are being used, therefore, carefully check the area before use. Also, if response seems slow during use, discontinue use as quickly as possible.
- If the 2.4GHz frequency band is saturated (too many radio controllers on at once), as a safety precaution, the radio control system may not bind. This ensures that your radio control system does not get hit by interference. Once the frequencies have been cleared, or the saturation level has dropped, your radio control system should be able to bind without any problems.
- Observe any applicable laws and regulations in place at your flying site when using the 2.4GHz radio control system.
- Unlike frequency bands used with earlier radio control systems, reception with this 2.4GHz radio control system can be adversely affected by large obstructions and concrete or steel structures between your model and the transmitter. Also, wire mesh and similar barriers can adversely affect operation. Keep this mind to ensure the safety of your model.

TRANSMITTER PRECAUTIONS

- Turn the transmitter ON first and then turn the receiver ON. After using your model, turn the receiver OFF first, then turn the transmitter OFF. It can be dangerous if you activate the components in reverse order as the servos may start up inadvertently.
- Before use, double-check that the transmitter and receiver batteries are sufficiently charged.

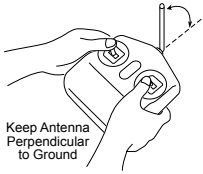

- Never touch the transmitter antenna during use. Doing so may cause loss of transmitter output, making it impossible to control your model.
- Before use, the transmitter antenna should be angled so that the antenna is as close to perpendicular to the ground as possible during use. This is the optimum angle for use. After use, to prevent any chance of damaging the antenna, the antenna should be moved into the horizontal stowed position.

SAFETY

- Be certain to read these Operating Instructions in their entirety.
- 'Safety First' for yourself, for others, and for your equipment.
- Observe all the rules of the flying site or anywhere you operate your radio control equipment.
- If at any time during the operation of your model should you feel or observe erratic operation or abnormality, end your operation as quickly and safely as possible. DO NOT operate your model again until you are certain the problem has been corrected.
- Your model can cause serious damage or injury, so please use caution and courtesy at all times.
- If you have little to no experience operating models, we strongly recommend you seek the assistance of experienced modelers or your local hobby shop for guidance.

BINDING THE RECEIVER TO YOUR TRANSMITTER

It is necessary to pair the transmitter and receiver to prevent interference from radio controllers operated by other users. This operation is referred to as 'binding'. Once the binding process is complete, the setting is remembered even when the transmitter and receiver are turned OFF, therefore, this procedure usually only needs to be done once for each separate receiver you're using.

 The Binding procedure describes binding the receiver to an Airtronics RDS8000 transmitter. If binding the receiver to an Airtronics SD-10G transmitter, please refer to the Transmitter and Receiver Binding section in your SD-10G Operating Manual.

IMPORTANT If binding the receiver to the Airtronics SD-10G transmitter, the SD-10G transmitter Modulation must first be changed to FH1. Refer to your SD-10G Operating Manual for more information.

1) Ensure that the throttle control stick is in the LOW position (pulled all the way back). In HELI mode, ensure that the Flight Mode switch is set to 'N' (Normal). Connect the switch harness, servos, and the receiver battery to the receiver, using the diagram on the previous page. Make sure that both the transmitter and the receiver are turned OFF.

2) Turn the transmitter ON. The Bind LED on the transmitter will illuminate solid blue.

3) While holding down the Bind Button on the receiver, turn the receiver ON. The Bind LED on the receiver will flash slowly. After ~2 seconds release the Bind Button. The Bind LED on the receiver will continue to flash slowly.

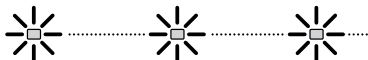
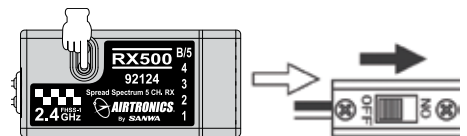

 Use the tip of a pencil or a 1.5mm hex wrench to press the Bind Button on the receiver.

4) Quickly press the Bind Button on the transmitter. The Bind LED on the receiver will flash rapidly for ~3 seconds, go out momentarily, then illuminate solid blue, indicating the binding process is complete.

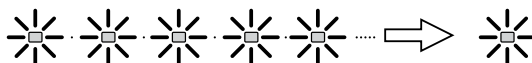

 When the binding procedure is successful, the Bind LED on the receiver will stay solid blue when both the transmitter and receiver are turned ON. If the Bind LED on the receiver is blinking rapidly or not ON at all, the transmitter and receiver are not paired. In this case, turn both the transmitter and receiver OFF, then repeat the binding procedure.

MOUNTING THE RECEIVER

When mounting the receiver into your model, it's important to mount the receiver exactly as described. In addition, the receiver should be wrapped in foam rubber to protect it from vibration. Failure to mount the receiver antenna wires as described can result in poor reception, or in some cases, complete loss of reception.

 We recommend that you bind the transmitter and receiver and program the Fail Safe function (see page 4) prior to mounting the receiver into your aircraft, otherwise, it may be difficult or impossible to access the Bind Button on the receiver.

The receiver should be mounted securely in your model and the receiver antenna wires installed per the diagram below. The two receiver antenna wires should be mounted to a wood or plastic non-conductive part of your model and angled so that the reception wires are positioned 90° apart.

 **The Coaxial cables can be mounted parallel to each other, but under no circumstances should the antenna reception wires be mounted parallel to each other.**

WARNING It is extremely important that the receiver antenna wires be mounted as described. This will ensure that your model receives control signals no matter what its posture, attitude, or heading.

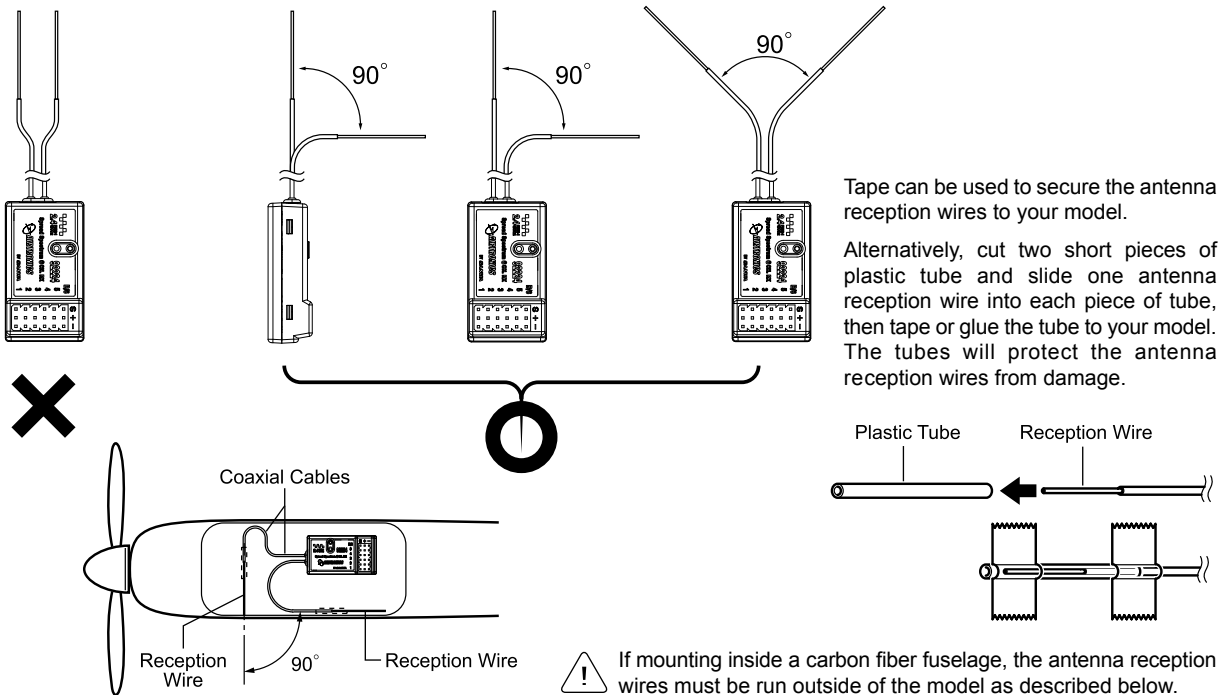

- The receiver antenna wires consists of two coaxial cables and two reception wires (the thin tip at the end of the coaxial cables). When you mount the receiver antenna wires, do not bend the reception wires. Reception performance decreases if the reception wires are bent.
- The receiver antenna wires are delicate, therefore, handle with care. Do not pull on the receiver antenna wires with force. Do not cut or extend the receiver antenna wires.
- The coaxial cables (the thicker portion of the receiver antenna wires) can be bent into gentle curves, however, do not bend the coaxial cables acutely, or repeatedly bend them, or the antenna cores can be damaged.
- When installed in an electric-powered model, keep the receiver antenna wires as far away from the motor, battery, and electronic speed control (ESC) as possible.
- There is a danger of runaway operation if connectors shake loose during use. Make sure that the receiver, servo(s), and switch harness connectors are securely fitted.
- The receiver is susceptible to vibration and moisture. Take appropriate measures to protect against vibration and moisture. The receiver should be wrapped in foam and the foam should be secured around the receiver to hold it in place. The foam should not be secured too tightly or the vibration dampening quality of the foam will be reduced. Failure to take appropriate measures could result in damage to the receiver.
- When installing the receiver, the antenna reception wires (the thin tip at the end of the coaxial cables) should not come into contact with any carbon or metal components (conductive components). Aircraft fuselages and helicopter frames may contain conductive components. If mounting the receiver surrounded by conductive materials (for example, a carbon fiber fuselage), mount the receiver so that the antenna reception wires can be extended outside of the model. Reception can be blocked if the antenna reception wires are shielded inside a carbon fiber fuselage.

SETTING THE FAILSAFE

The Fail Safe function automatically sets the servos to a predetermined position in the event that the signal between the transmitter and the receiver is interrupted, whether due to signal degradation or to a low transmitter battery. For example, the Fail Safe can be set so that the throttle servo returns to low, the elevator moves slightly up, and the ailerons move slightly right or left, to result in a shallow decent.

 Programmable Fail Safe is available on channels 1 through 4 only.

- 1) Drop the throttle control stick all the way back to the Low Throttle position, then turn the transmitter ON.
- 2) Turn the receiver ON. The Bind LED on the receiver should illuminate solid blue, indicating that the transmitter and receiver are paired, then move the transmitter control sticks to verify that the servos are operating.

 The Fail Safe settings will be erased if you re-bind the transmitter and receiver pair. If you bind the same transmitter and receiver pair you **MUST** repeat these procedures to setup the Fail Safe function again.

- 3) Move the transmitter control sticks to the desired Fail Safe position. While holding the transmitter control sticks in those positions (generally throttle at idle and a minimal amount of elevator and/or aileron), press and hold the Bind Button on the receiver. After ~2 seconds, the Bind LED will begin to flash slowly. Continue holding the Bind Button until the Bind LED begins to flash rapidly (~2 more seconds). Once the Bind LED begins to flash rapidly, release the Bind Button.
- 4) Turn the transmitter OFF to test Fail Safe operation. The servos should move to the positions that you set in step 3.

RANGE CHECKING - LOW POWER MODE

IMPORTANT The radio control system should be range checked prior to the day's first flight and prior to the first flight after a hard landing or after a repair. This will ensure that the transmitter and receiver are communicating properly prior to flight. This ensures the safety of your model, yourself, and the people around you.

 The Range Checking procedure describes using the receiver with an Airtronics RDS8000 2.4GHz transmitter. If using the receiver with an Airtronics SD-10G 2.4GHz transmitter, please refer to the Range Checking section in your SD-10G Operating Manual.

- 1) Press and hold the Bind Button on the transmitter, then turn the transmitter ON. Continue to hold down the Bind Button for ~5 seconds. The Bind LED will flash slowly during this time. After ~5 seconds the Bind LED will flash rapidly, then go out. Release the Bind Button and the Bind LED will continuously flash rapidly. The transmitter is now in Low Power Mode.

 The transmitter will stay in Low Power Mode for 3 minutes. After 3 minutes, the transmitter will revert to Normal mode.

- 2) Turn the receiver ON in your model.
- 3) With the transmitter in Low Power Mode, walk approximately 30 paces from your model (approximately 90 feet) and, with the help of another person, check to make sure that the servos move without any problems. If there is a problem with servo movement, try moving to a different position while still maintaining the same distance from your model, then check servo movement again. If there is still a problem, **DO NOT FLY**. Check to make sure that all receiver, servos, switch, and onboard battery connections are correct and secure. Check to ensure that the antenna wires are correctly mounted.
- 4) After you have completed your range check, turn the transmitter OFF, then turn the transmitter ON to revert back to Normal Mode.

Do not attempt to fly with the transmitter in Low Power Mode. You will be unable to control your model once it is a certain distance away from you. Before you fly, make sure that the transmitter Bind LED is illuminated solid blue!

POWER MODE	TX BIND LED STATUS
Low Power Mode	Blue - Flashing Rapidly
Normal Mode	Blue - Illuminated Solid

 If, after checking all airborne system components and verifying correct antenna wire mounting, your radio control system still fails the Range Check, **DO NOT FLY**. Please contact Airtronics Customer Service.



Airtronics is Distributed Exclusively in North America by:

Global Hobby Distributors
18480 Bandilier Circle
Fountain Valley, CA 92708

Telephone: (714) 963-0329
Fax: (714) 964-6236
Email: service@airtronics.net